



THE EFFECTIVENESS OF RIGID ROTOR'S BALANCE WITH RESONANT EXTORTION OF THE SYSTEM WITH SMALL DAMPING

Janusz Zachwieja, Henryk Holka

*University of Technology and Life Sciences in Bydgoszcz
ul. S. Kaliskiego 7, 85-789 Bydgoszcz, Polska
email: jz@zmp.com.pl*

Abstract

The thesis refers to the previous researches of the authors of the dynamics of rigid rotor placed on favourable ground. Such systems are characterized by usually low frequency of normal mode vibrations which causes real danger that they can work in the resonant region or cross this region every time during acceleration or start. The amplitude of rotor's vibrations with small internal damping reaches then high values. The factor of damping for the system with small mass may be defined on the basis of the character of its response to pulse extortion. The way how to determine the value of rotor's damping useful for the numerical analysis of its vibration was presented. The thesis presents also the results of the researches of the effectiveness of disk balance with circum-resonant speed in the situations when only unbalanced force affects the rotor and when vibrations of the foundation are caused by the external resonant induction.

Keywords: rigid rotor balancing natural frequencies vibrations

1. Introduction

The foundations of the machines are sometimes characterized by relatively high susceptibility and small damping because of which the amplitude of their vibrations may reach high values even with small extortion [1]. The supporting construction of the separator presented in the Fig. 1.1 is an example of incorrect approach to the way of designing depending on taking into account only the aspect of endurance and excluding the conclusions drawn from the analysis of normal mode vibrations of the construction [2]. Low rigidity of the foundation of bicarbonate separator (Fig. 1.2) is the consequence of thoughtful action and results from the necessity of providing the machine with the accurate vibration isolation [3].

If the frequency of normal mode vibrations of the foundation is low there is a greater danger that lying on it rotor machine will incur vibrations of resonant character during work as well as during acceleration or start. The frequencies of extortions affecting the foundation result from speed motor drive (25Hz or 50 Hz) if the unbalanced rotor is directly connected to the motor or they may be completely arbitrary if there is a gear in the motor drive system. In numerous situations several machines of one processing line are placed on the same foundation, constituting a disturbance for each other (Fig. 1.3).



Fig. 1.1. The view of the separator's springer construction



Fig. 1.2. The manner of bicarbonate centrifuge founding



Fig. 1.3. A row of ventilators placed on a common foundation

Resonant qualities of the system and its damping are features between which there is a great co-dependence. The bigger damping, the less clear response of the resonant system. Resonant vibrations of the construction, besides the case of its vibratory stress relief [4,5], are harmful and may lead to the catastrophe caused by big deformations of its elements and subsidence of the foundation which supports it [6].

Vibrations are the main cause of reducing vivacity of machine's elements, especially bearings. Usually the rotating parts are not allowed to work in their resonant region. The deviation from the rule are operating conditions of turbine's rotor which frequency of normal mode vibrations is only slightly lower than rotational frequency. It is the feature of flexible rotors owing to which they are subject to self-aligning after crossing critical speed. Anisotropy of rotor's rigidity causes growth of the number of resonant frequencies between which there are regions of backward precession [7]. It means that the rotor is exposed to be in the regions of prohibited speed several times.

Rotor's balance with the circum-resonant speed encounters numerous difficulties mainly because of instability of the amplitude as well as its angles of phase vibration. Its effectiveness in most cases is not satisfactory and it is necessary to include in the method of impact factors special averaging algorithms in order to improve the accuracy of calculations when determining correlation masses [8,9].

2. The analysis of impact of damping on rotor's vibration in the region of resonance occurrence

When modelling vibrations of rigid rotor it is convenient to treat all elements of the system as non-deformable bodies with the exception of elements which susceptibility has an impact on the character of its functioning. Coupling and vibroisolators belong to the group. In the case of the later their rigidity is usually known although the values given by the producer slightly vary from the once obtained during verifying researches. The value of damping is unknown. If the rotor is placed directly on the foundation, the susceptibility of the foundation is the unknown which should be defined. The possible procedure is exemplified by the rotor presented in the Fig. 2.1. It has 2 disks which are the correlation surfaces during balance. The drive from the motor with the adjustable rotational frequency is transferred to the rotor by rigid coupling of Rotex type with polyurethane footbed with hardness of 92°Sh. On the frame, together with the rotor there is an inductor with forced frequency adjustable by frequency converter. The total mass of the stand is ~120 kg. The frame is placed on the favourable ground.



Fig. 2.1. Test stand: 1. two-disk rotor, 2. motor, 3. coupling, 4. indicator, 5. frame, 6. favourable ground

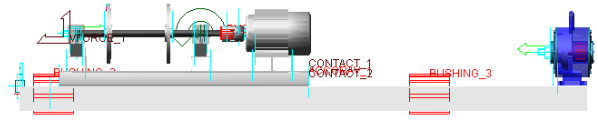

Fig. 2.2. Numerical model of the test stand

The resonant characteristic of the rotor was determined in two ways: by pulse induction and by using short-term Fourier transform for the analysis of time course of vibrations during the start of the inductor. According to the expectations, the basic resonant frequencies of rotor's vibrations are low and amount to: horizontal surface - ~6Hz, vertical surface --11 Hz (Fig. 2.3.).

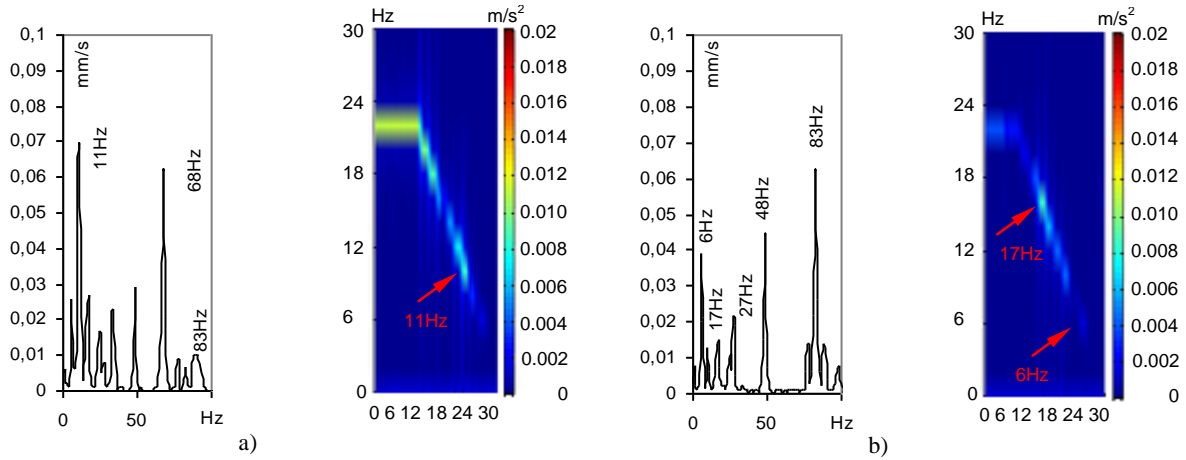

Fig. 2.3. Resonant characteristics of rotor's vibrations determined during the start of the inductor: a) vertical surface, b) horizontal surface

To describe the qualities of the rotor the so-called flat model was used, which equations of movement can be presented by coordinates complex as [10]

$$m\ddot{x} + c_x\dot{x} + k_x x = \varepsilon m \Omega^2 \cos(\Omega t) \quad \text{and} \quad m\ddot{y} + c_y\dot{y} + k_y y = \varepsilon m \Omega^2 \sin(\Omega t) \quad (2.1)$$

Assuming signs $z = x + iy$, $\bar{z} = x - iy$ and multiplying by i The second equation and adding to both sides of equation we receive

$$m\ddot{z} + c_s\dot{z} + c_d\dot{\bar{z}} + k_s z + k_d \bar{z} = \varepsilon m \Omega^2 \exp(i\Omega t) \quad (2.2)$$

where $c_s = \frac{c_x + c_y}{2}$ and $c_d = \frac{c_x - c_y}{2}$, as well as $k_s = \frac{k_x + k_y}{2}$ and $k_d = \frac{k_x - k_y}{2}$, moreover: m – rotor's mass, c_x, c_y – damping factor, k_x, k_y – rigidity, $\varepsilon = |\varepsilon|$ - vector module of the location of the rotor's centre of gravity against the axis of rotation, Ω - angular velocity.

The rigidity of the rotor's foundation may be determined if we know its mass and resonant frequencies. For example, the model presented in the Fig. 2.2 has, with the same mass as the rotor, similar resonant frequencies if the rigidities of the bearing are adequately 100N/mm in horizontal direction and 300N/mm in vertical direction. Corresponding to them normal forms are presented in the Fig. 2.4. The amplitude-frequency characteristic in the range of frequency (0-20 Hz) confirms the result received earlier by the use of inductor (Fig. 2.5b).

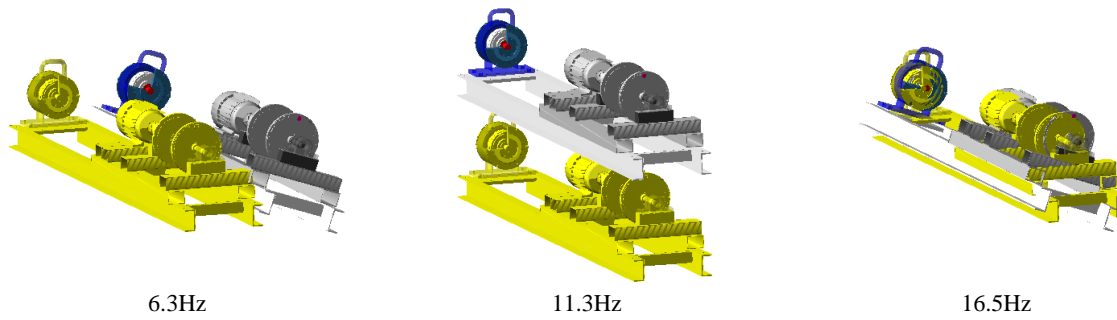

Fig. 2.4. The forms of norma mode vibrations – equilibrium position marked yellow

The bigger problem is to estimate the value of damping. The possible way to define it is to determine the logarithmic decrement. The system with one degree of freedom which response to the implemented extortion is described by harmonic function, there are dependencies between the damping factor, mass and logarithmic decrement.

$$h = \frac{c}{2m} \quad \text{and} \quad \delta = \ln\left(\frac{A_i}{A_{i+1}}\right) = h \frac{T}{2} \quad (2.3)$$

Converting the compounds (2-3) we receive the dependencies of damping factor in the form of

$$c = \frac{4m\delta}{T} \quad (2.4)$$

Here: δ - logarithmic decrement, T – vibrations period.

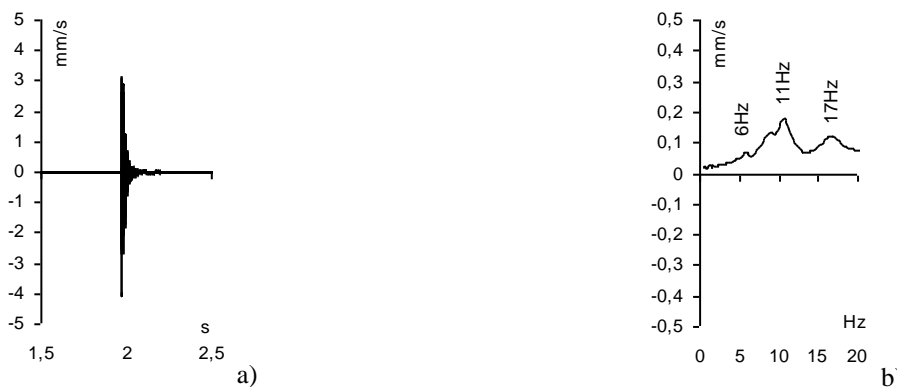

Fig.2.5. The response of the system to pulse induction: a) time course, b) characteristic A-C

The analysis of the rotor's response to the pulse induction defines logarithmic decrement with the precision sufficient to the accurate estimation of the value of factor c . For example, the response of the system to pulse induction in vertical direction is shown in Fig. 2.5a.

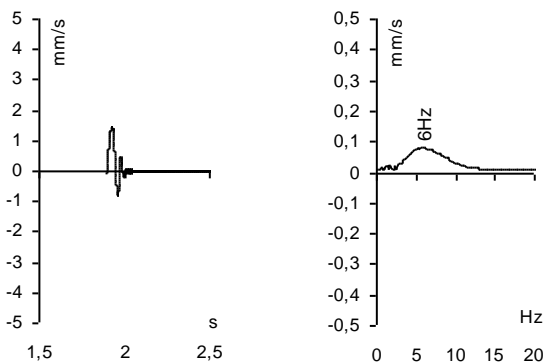

Fig.2.6. The figure of the system's response in horizontal direction after Hilbert-Huang transform

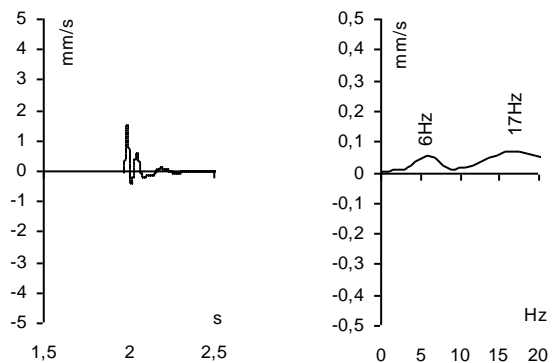

Fig. 2.7. Numerical solution of the system's response in horizontal direction for the approved model

We will obtain the character of rotor's vibrations in natural frequencies after putting on the signal the narrow-band filter. This function is served well by Hilbert-Huang transform. Fig. 2.6 and 2.8 present the effect of the filtration of the signal presented in the Fig. 2.5 to obtain a clear course of the response of the system in frequencies of 6 Hz and 11 Hz. The use of the filter allows the analysis of the character of rotor's vibrations in orthogonal directions by the induction only in the direction of its smaller rigidity. It is crucial in the case of anisotropic susceptibility of bearing with great asymmetry requiring the use in the direction of bigger rigidity greater force to obtain a clear response of the system to the induction. Comparing the shape of the functions crucial (IMF - *Intrinsic Mode Functions*). for resonant frequencies with time course of the response obtained from numerical solution of the model's vibrations, a great similarity for damping factor 1 Ns/mm in horizontal direction (Fig. 2.6s and 2.7a) and for damping factor 2 Ns/mm in vertical direction (Fig. 2.8a and 2.9a) can be observed.

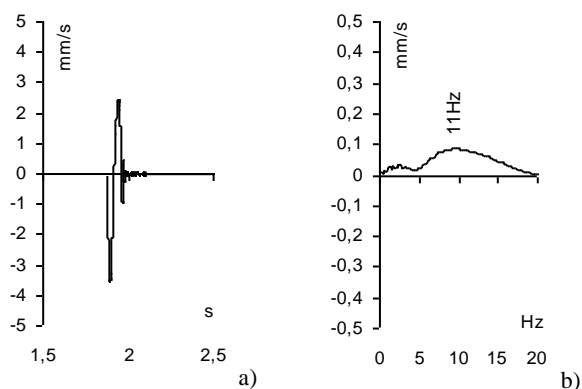

Fig. 2.8. The figure of the system's response in vertical direction after Hilbert-Huang transform

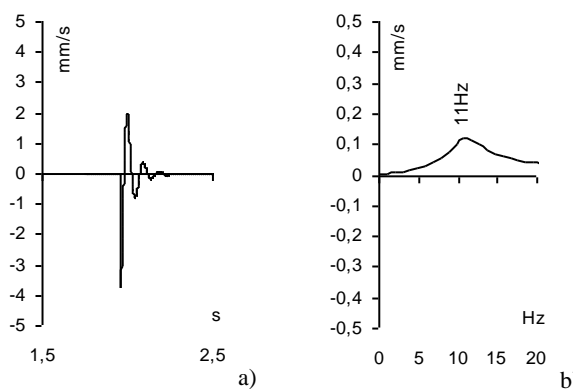

Fig. 2.9. Numerical solution of the system's response in horizontal direction for the approved model

The final verification of the accurate choice of physical parameters of the model is the accordance of the shape of time course of rotor's vibrations speed during a run-up with numerical solution for an analogous case (Fig. 2.10a – 2.10b). As we can see such big damping of the system causes crossing the resonant region by the rotor during a run-up in a gentle way.

Having the proper model available, we can conduct the stimulation showing the impact of the damping on the rotor's behaviour when it is crossing the resonance for the equal damping values. The similar analysis should proceed the choice of vibro-isolators every time, especially if they have damping qualities (the so-called viscous damper).

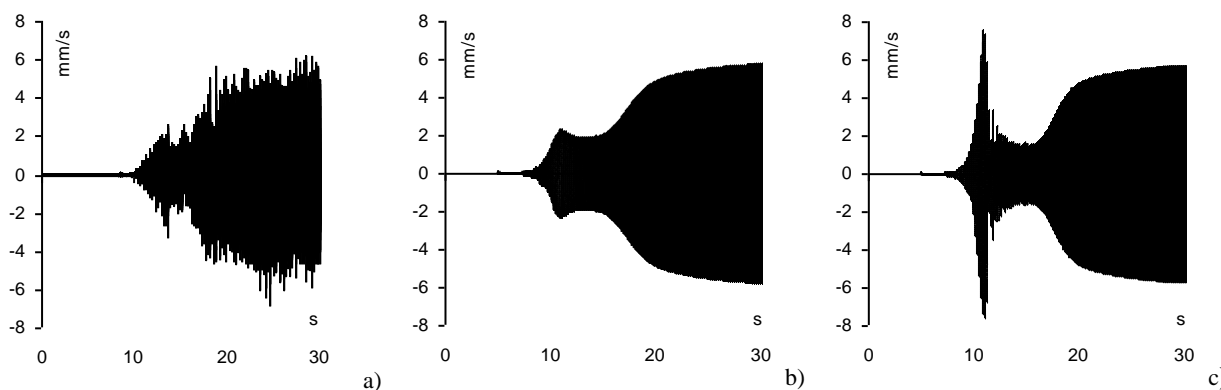

Fig. 2.10. Time courses of vibrations of: a) rotor, b) its model with similar rigidity and damping, c) rotor's model with small damping

Fig. 2.10c shows the anticipated time course of rotor's vibrations with unbalanced disk during acceleration to rotational frequency of 25Hz when the damping factor equals 0,1 Ns/mm. Its ten

times smaller value than the actual one does not have a significant impact on the level of the forced vibrations, but the amplitudes of vibrations in the resonant region increase significantly.

3. Rotor's balance outsider the resonant region

In order to examine the impact of induction of natural frequency on the course and obtained quality, the rotor was balanced in two phases. First, with the rotational frequency of 15 Hz without additional extortion affecting the rotor, and then with additional induction of circum-resonant frequency of 10,5Hz. Unbalancing of the rotor was the result of attaching to the disk K_1 mass $m_n=(20g<90^0)$. The amplitude-frequency characteristics presented in Fig. 3.1 show this dynamic condition.

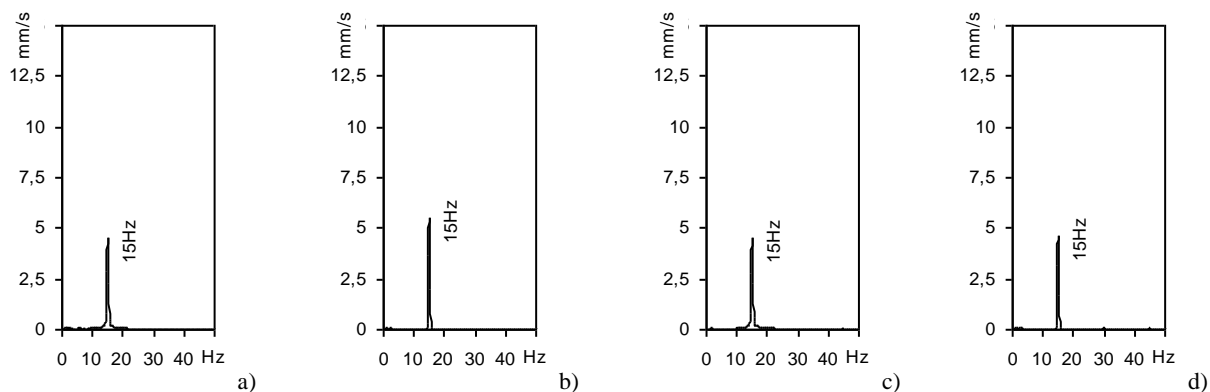

Fig. 3.1. The amplitude-frequency characteristics of rotor's vibrations speed with rotational frequency of 15 Hz and unbalance of 20g mass attached to the disk K_1 .

The result achieved by balancing the rotor with the optimisation of the value of the amplitude of both bearings movement is presented by holospectra 1x (Fig. 3.2-3.3). The optimisation algorithm P(1,2,3,4) used for the correlation K(1) using the disk to which the mass m_n is attached, determined the correcting mass $m_k=(22.3g<260^0)$. The achieved result is correct and the slight difference does not result from calculation error, but from the existing initial unbalance of the disk (Fig. 3.2).

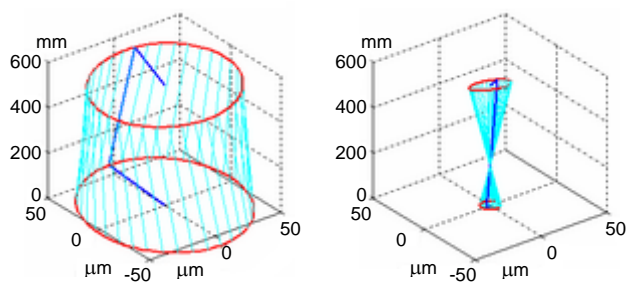

Fig. 3.2. The comparison of the rotor's movement in Bearing surfaces a) initial state, b) after the balance, without additional extortion of foundation vibrations

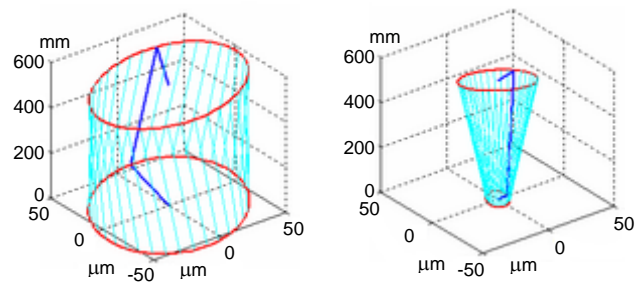

Fig. 3.3. The comparison of the rotor's movement in bearing surfaces a) initial state, b) after the balance, without additional extortion of frame vibrations of frequency of 10.5Hz

The repeated process of balancing with the same frequency and additional induction resulted in what is presented in Fig. 3.3. The picture of the dynamic condition of the rotor before the balance is presented in Fig. 3.4 in the form of the amplitude-frequency characteristic of vibrations speed.

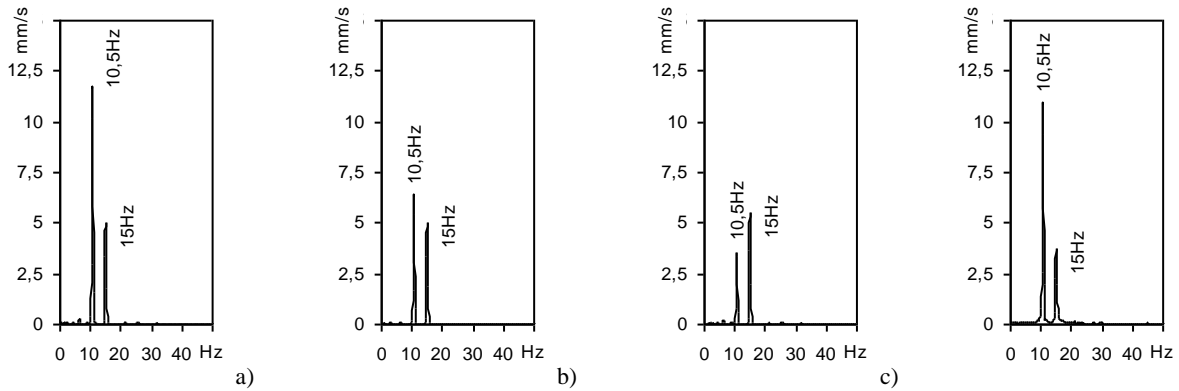

Fig. 3.4. The amplitude-frequency characteristics of vibrations speed of the rotor with the rotational frequency of 15 Hz and the unbalance of 20g mass attached to The disk K_1 induction with frequency of 10.5 Hz

Circum-resonant induction caused the deterioration of the achieved balanced quality. It can be seen especially with reference to the vibrations of the bearing placed further from the correlation surface.

4. Balance in the resonant region

The essence of the resonant vibrations is that even small extortion reflects in the response of the system with high amplitude values. When balancing the rotor we are usually not aware that its rotational frequency is close to natural frequency and the unbalance has secondary meaning. We expect to achieve the effect in the form of multiple decrease of the level of vibrations. It causes the situation in which we manage to limit this level, but further action proves to be ineffective. The calculated correcting mass causes another balancing of the rotor so that another one improves its dynamic condition.

Coaxial rotor with significant static unbalance can be balanced to a certain extent in the resonant region. To determine it to the disk K_1 of the rotor presented in Fig. 2.1 $m_n=(20g<90^0)$ mass was attached. The achieved balance quality may be estimated comparing 1x holospectra of the rotor presented in Fig. 4.1-4.2 adequately for the circum-resonant frequencies 10,5 Hz and 6 Hz. Although the rotor's balance took place in the region of forced vibrations along with normal mode vibrations, two- and four-fold decrease of their level was achieved. It is not the satisfactory result if we compare it to the effect achieved during the balance of the rotor outside the resonant region.

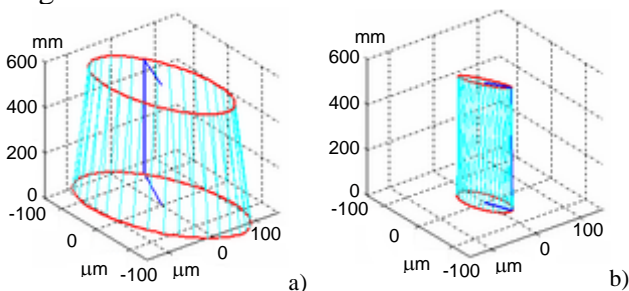

Fig. 4.1. The rotor's holospectrum before and after the balance with the frequency of 10.5Hz

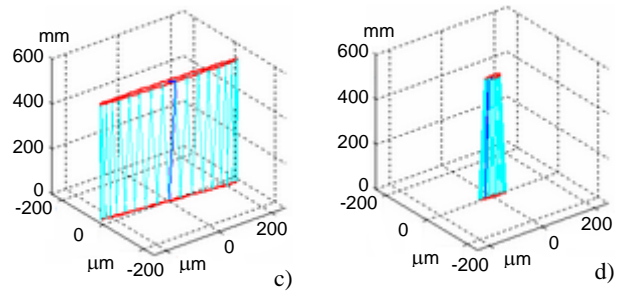

Fig. 4.2. The rotor's holospectrum before and after the balance with The frequency of 6Hz

The analysis of the effectiveness of the balance in the resonant region of the rotor with the unbalance torque attaching to both disks the masses $m_{n1}=(10g<90^0)$ and $m_{n2}=(10g<270^0)$ was conducted. They have identical values, however their peripheral location on the disk of the rotor vary by π angle. The extortion caused by such load during the rotor's rotation comes down to double force action. The balance was conducted with frequencies of 6 Hz, 8 Hz, 11 Hz and 15 Hz

so in the resonant regions, but also between them – in the conditions of backward precession, as well as the above second resonant frequency. Fig. 4.3-4.6 present the results.

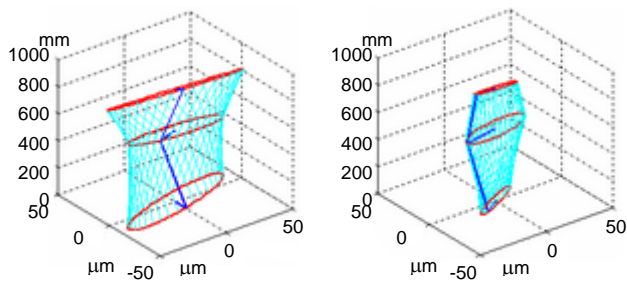

Fig. 4.3. The rotor's condition with the unbalance torque before and after the balance with 6Hz frequency

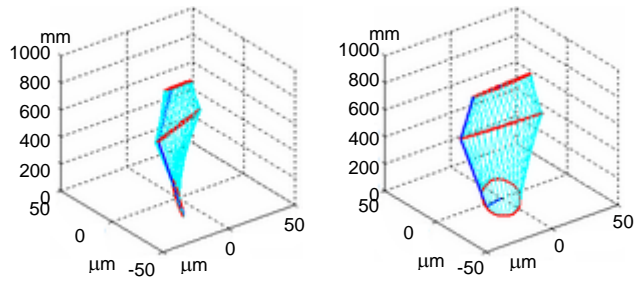

Fig. 4.4. The rotor's condition with the unbalance torque before and after the balance with 8 Hz frequency

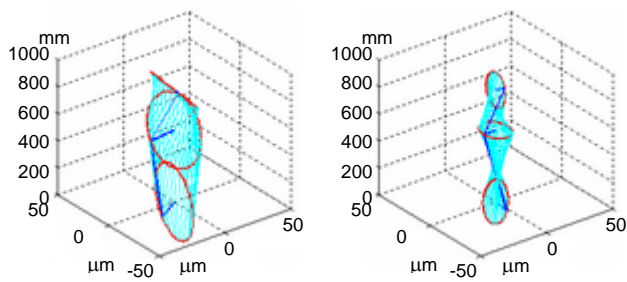

Fig. 4.5. The rotor's condition with the unbalance torque before and after the balance with 11 Hz frequency

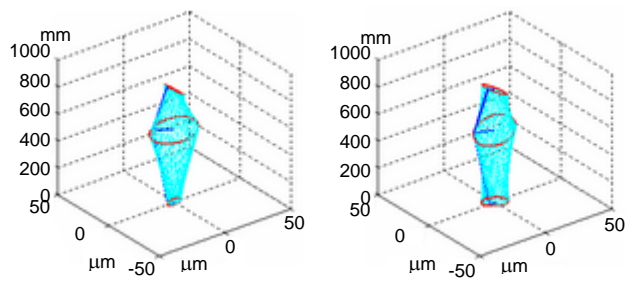

Fig. 4.6. The rotor's condition with the unbalance torque before and after the balance with 15 Hz frequency

The result of the experiment is extremely interesting because of the fact that the clear decrease of the rotor's vibrations with the unbalance torque was achieved with critical velocity.

5. The balance of the rotor in the resonant region with the natural frequency induction

An interesting case was observed during the rotor's balance with circum-resonant frequency of 10,5 Hz. The system was additionally inducted with synchronous frequency. To the disk K₁ 20g mass constituting its initial unbalance was attached.

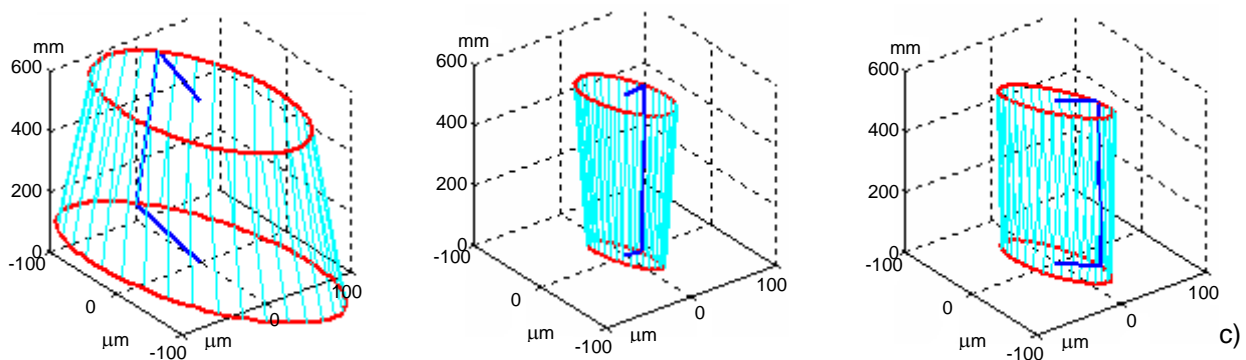

Fig.5.1. Holospectrum of the rotor's vibrations with frequency of 10,5 Hz a) initial state, b) after the balance, c) after switching off the inductor

The fact that the rotor's balance was conducted with the resonant frequency did not disrupt its course, but it is hard to recognize the achieved effect as satisfactory. After the induction stopped the amplitudes of vibrations in the direction of resonance occurrence increased. The occurrence of

such effect means that the algorithm of the method of impact factors determines correlative masses based on the actual character of the rotor's vibrations. Its change may sometimes cause unexpected results.

6. Conclusions

The construction of the correct numerical model of the rotor requires the knowledge of its basic features such as mass, rigidity and damping. The rigid rotor may be treated as a compound system composed of non-deformable bodies because of the fact that the susceptibility of the rotor's shaft and disk is definitely smaller than in the case of the shoring. It definitely limits the number of freedom degrees and modelling process becomes relatively simple. The main problem still is the determination of its physical qualities such as rigidity and damping. It can be solved thanks to the knowledge of resonant characteristic of the actual system determined on the basis of pulse extortion. Knowing the rotor's mass and frequency of normal mode vibrations it is easy to estimate the rigidity occurring in the system and by determining the logarithmic decrement we receive approximate values of damping factors. This method can be used to examine the qualities of rotors with small mass and rigidity. Choosing the type of vibro-isolators it is necessary to remember that their damping qualities allow to reduce the amplitudes of the rotor's vibrations mainly with the natural frequency. The effect in the form of limiting the level of forced vibrations is not significant. The balance of the rigid rotor in the resonant region causes the fact that the achieved quality is not satisfactory. External extortion with resonant frequency reduces the effectiveness of the balance even more.

References

- [1] Holka H., Effect of support structure receptance on mechanism operation. *Developments in Machinery Design and Control* 1, 41-49. 2005.
- [2] Zachwieja J., Gołębiowska I., Damping of structures free vibrations based on the example of steel structure of separator's foundation. *Developments in Machinery Design and Control – Nowogród*. 2008.
- [3] Zachwieja J., Peszyński K., *Vibroisolators application for damping vibrations in industrial fans*. National Conference with International Participations – Engineering Mechanics Svratka Czech Republic. 2008.
- [4] Zachwieja J., *Diagnozowanie procesu odprężania wibracyjnego konstrukcji stalowych w celu doboru optymalnych parametrów technologicznych*, *Elementy diagnostyki maszyn roboczych i pojazdów*, 283-294. 2009.
- [5] Holka H., Nieckarz M., *Usuwanie naprężeń spawalniczych w stalowych konstrukcjach metodami wibracyjnymi*. *Postępy w sterowaniu i konstrukcji – Bydgoszcz* 2001.
- [6] Zachwieja J., Numerical modelling of vibrations of machine foundations with percussive characteristics of work. *Developments in Machinery Design and Control* 5, 83-96. 2007.
- [7] Muszyńska A., *Rotordynamics*. John Wiley & Sons Inc. 2005.
- [8] Kang Y., Liu C.P., Sheen G., *A modified influence coefficient method for balancing unsymmetrical rotor-bearing systems*. *Journal of Sound and Vibration* 194(2), 199-218. 1996.
- [9] Lees A. W., Friswell M. I., The evaluation of rotor unbalance in flexibly mounted machines. *Journal of Sound and Vibration* 208, 671-683. 1997.
- [10] Genta G., *Whirling of unsymmetrical rotors: A finite element approach based on complex coordinates*. *Journal of Sound and Vibrations* 124(1), 27-53. 1988.

